

- // Designed to process all types of thermoplastic materials
- // Full automated product handling
- // Labor free handling with high hygienic
- // Optimized cycle speed with lower production costs
- // Multiple row moulding



The F87 is a fully automatic, electro mechanically driven, thermoforming machine with in-mould trim, which nullifies shrinkage effects on trim accuracy. It has been designed to process all types of thermoplastic materials.

The F87 forming station and automatic product handling is designed for multiple row moulds, in-line and/or staggered layout. The international patented "vacuum plate" and unloading system, including stacking and counting, provides a labor free handling with high hygienic.

The F87 design incorporates the "Smart Drive" and the moving parts in automated product handling are made of light weight, durable carbon fibre material, which assures optimized cycle speed with lower production costs.

The "Smart Drive" consists of:

- // **Drives:** CNC Axis control for all motors connected to electronic cams.
- // **Sequencing:** Operator has screen access to all machine functions with precision time settings available.
- // **Recipe Card:** it assures repeat settings and quick mould changes.
- // **Storage:** for important maintenance records & production information.

wifag//polytype group

F87 – think big



Polytype AG
26, route de la Glâne
CH-1701 Fribourg/Switzerland

Phone +41 26 426 11 11

info@polytype.com
www.polytype.com

OMV MACHINERY S.R.L Italy
Lungadige Attiraglio 67
I-37124 Parona - Verona/Italy

Phone +39 045 83 94 444

info@omvgroup.com
www.omvgroup.com

SWITZERLAND

WIFAG-Polytype Holding AG
Fribourg/Switzerland

Polytype AG
Fribourg/Switzerland

ITALY

OMV Machinery srl
Verona/Italy

BULGARIA

Mechatronica S.C.
Gabrovo/Bulgaria

AMERICA

Polytype America Corp.
Lincoln Park, NJ/USA

ASIA

Polytype Asia Pacific Co., Ltd.
Chachoengsao/Thailand

Wifag-Polytype India Marketing Private Ltd.
New Delhi/India

The ultimate large universal thermoformer

Especially designed for high production requirements

- // Unique RIM-rolling device for cups to be placed on request
- // Capability to form the widest range of cups and containers
- // Controlled access to all machine functions about the panel
- // Repeated settings and quick mould changes

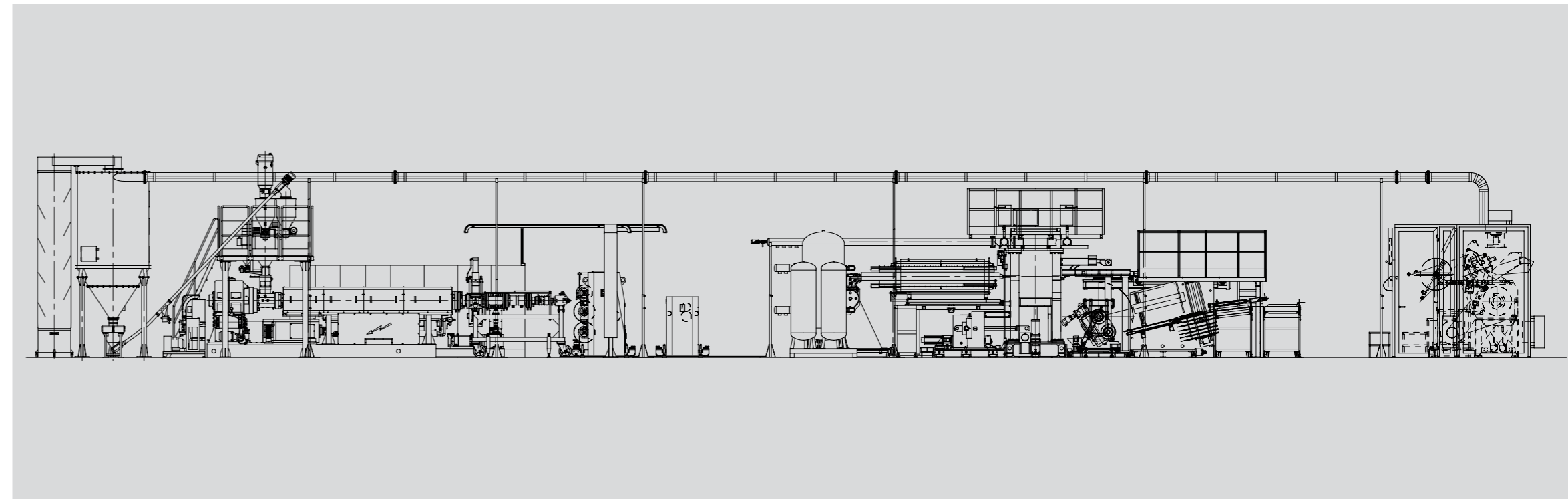
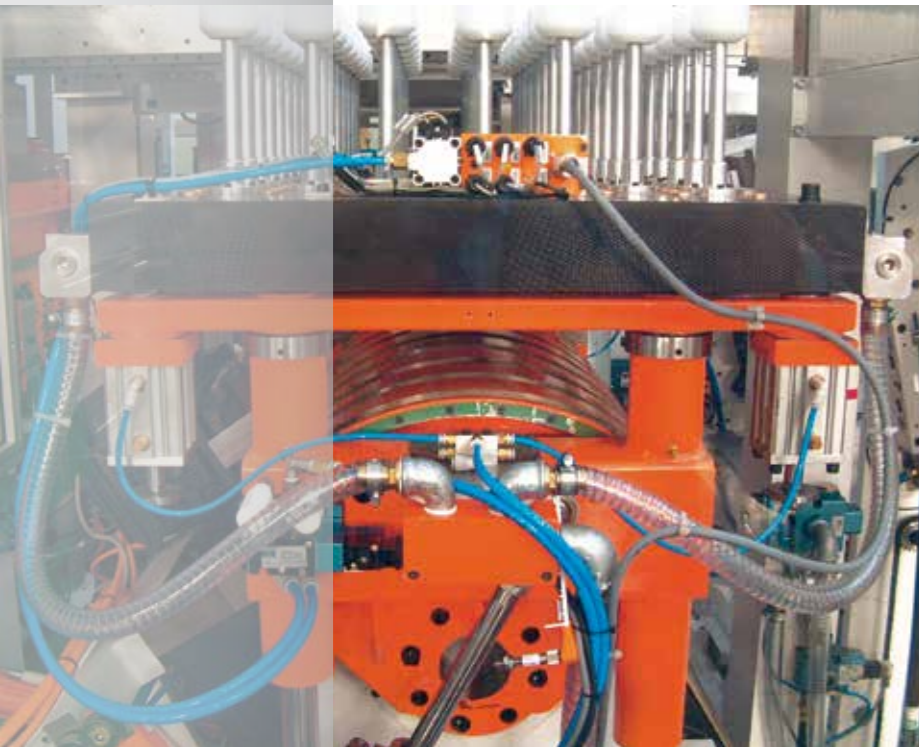

- // Electronic servo drive with profiled acceleration/ deceleration torque
- // The chain rails can be retracted away from the form station, during mould change, for easy access
- // Oven (Heating elements)
- // C shape oven with top and bottom ceramic heater elements arranged in longitudinal and transversal zones
- // Special features are built into the oven to avoid sag problems typically experienced in traditional ovens
- // Sheet edge preheaters, located at the entrance of the oven
- // Forming station
- // Platen movement is driven by a toggle/cam assembly where the trim is operated by an independent hydraulic action without load drive cams/shafts
- // The lower platen is driven by a brushless servo motor. During the forming/trimming phase, motor stops, reverts and after the end of the forming cycle it begins a new cycle. The stroke of the lower platen is adjustable depending on product height (depth of draw).

Plug assist
Third motion servo driven plug assist independent from platen movement assure optimum process window.

Technical Specifications of F 87 THERMOFORMER - In Mould Trim		
Materials PS - PP - ABS - PET - PE - PLA		
Max. forming area	mm	850 x 650
Max. sheet width	mm	920
Sheet thickness	mm	0,2 - 2,8
Max. forming depth	mm	1° = 117 2° = 207
Max. positive forming	mm	15
Forming with compressed air	bar	6
Dry cycles	strokes/min	38
Oven size	mm	2.800 x 1.100
Mould closing force/Cutting force	daN	80.000
Max. cutting length	mm	20.000
Max. air consumption	NI/min	20.000
Max. cooling required (at 8°-10°C)	kcal/h	100.000
Max. vacuum consumption	m3/h	230
External dimensions	mm	12.000 x 7.500 x 4.000
Total installed motor power	kW	100
Total installed heating power	kW	180

SELECTION OF MOST WIDELY USED PRODUCTS - CHARACTERISTICS						
Shape	USE	Dimension mm	Content	N. of Cavities	Cycles/min.	Production/hour
	DRINKING CUP	Ø 71	200 cc	72 S	28	121.000
	DRINKING CUP	Ø 78	300 cc	56 S	24	81.000
	DRINKING CUP	Ø 95	600 cc	42 S	20	50.400
	YOGURT CUP	Ø 75	150 cc	63 L	21	79.400
	DELI CONTAINER	Ø 116	400 cc	24 L	22	31.700
	MARGARINE TUB	Ø 127	500 gr	20 L	19	22.800
	YOGURT CUP LID	Ø 77		48 L	23	66.200
	MARGARINE CUP LID	Ø 129		20 L	20	24.000
	MARGARINE CUP LID			20 L	22	26.400